

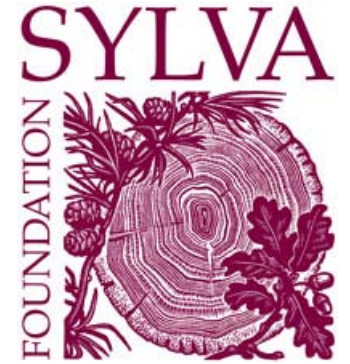

OneOak sawn timber catalogue



www.OneOak.info





Low grade character oak from the OneOak tree.

FSC certified source, Blenheim Estate. FSC Certified Sawmill.

Deep in Wood sawmill. Owner: James Binning Tel 01865 390268 website: www.deepinwood.co.uk

First length 4500 mm

Tag 00097 D.I.W.

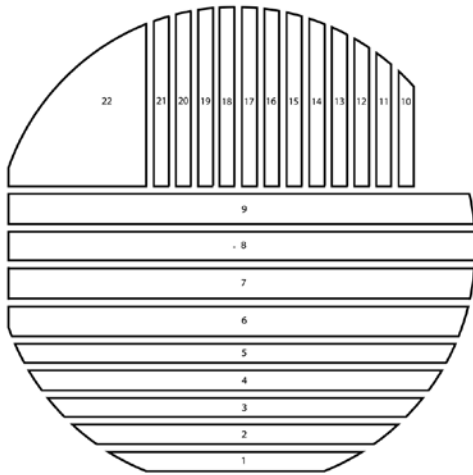

Second length – 4350 mm

Tag 00098 D.I.W.

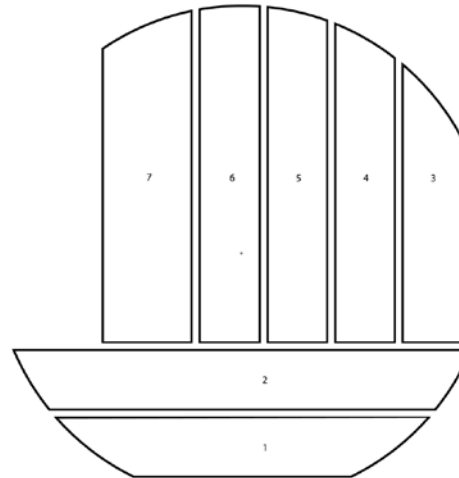





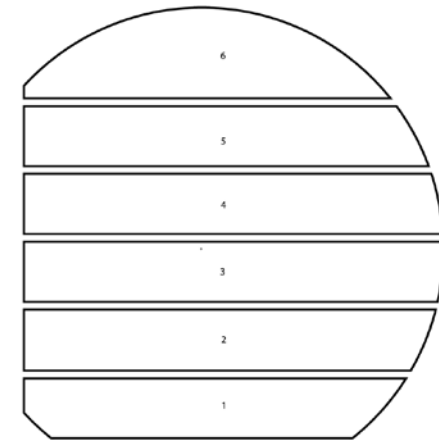

Third length – 2750 mm

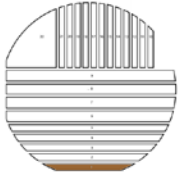

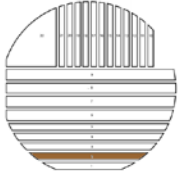

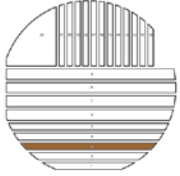

Tag 00099 D.I.W.



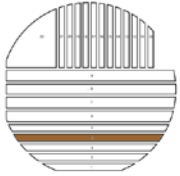

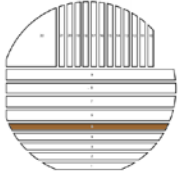

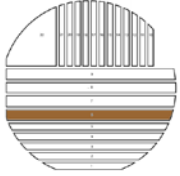

OneOak sawn timber catalogue

#	Board position	Photograph	Dimensions l × mean w × t mm	Description	End User Check online catalogue for latest details
1.1			4500 × 660 × 35	<ul style="list-style-type: none"> • Brown oak staining • 3 large knots in top metre • 40% sapwood 	Elliot & Co. OutoftheWood - speculative piece. Derek Elliot
1.2			4500 × 740 × 35	<ul style="list-style-type: none"> • 1.5m brown staining in first metre • Similar knots in top metre as in 1.1 • 30% sapwood 	Elliot & Co. OutoftheWood - speculative piece. Derek Elliot
1.3			4500 × 770 × 35	<ul style="list-style-type: none"> • Wider board • Similar staining to 1.2 • Knots in top metre tighter and more decorative than in 1.2 	Elliot & Co. OutoftheWood - speculative piece. Derek Elliot

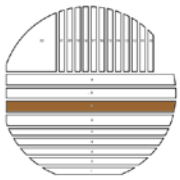

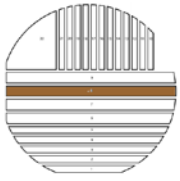

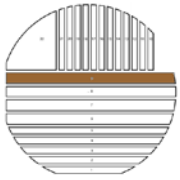

OneOak sawn timber catalogue

#	Board position	Photograph	Dimensions l × mean w × t mm	Description	End User Check online catalogue for latest details
1.4			4500 × 785 × 35	<ul style="list-style-type: none"> • Similar to 1.3 • Top end more tight clusters • Even more decorative – some cats paw 	Philip Koomen Furniture – speculative piece. Philip Koomen
1.5			4500 × 790 × 35	<ul style="list-style-type: none"> • First half stained brown in centre • Top half has tight knots and more character than 1.4 • Less sapwood than 1.4 	Philip Koomen Furniture – speculative piece. Philip Koomen
1.6			4500 × 805 × 50	<ul style="list-style-type: none"> • Brown staining through more than half of length • Four large tight knots in second half – some interesting figure around them • Marginal sapwood 	Christina Mackie - sculptor artist. Christina Mackie

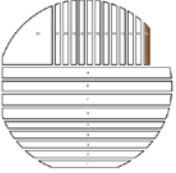

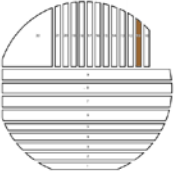

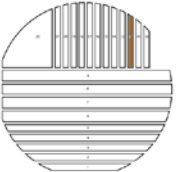

OneOak sawn timber catalogue

#	Board position	Photograph	Dimensions l × mean w × t mm	Description	End User Check online catalogue for latest details
1.7			4500 × 800 × 50	<ul style="list-style-type: none"> • 300mm shake in first half • Staining is reduced compared to earlier boards • Some shake in second half 	Dunford Woodwork - door & frame. Rollo Dunford Wood
1.8			4500 × 795 × 50	<ul style="list-style-type: none"> • Centre board • Pronounced medullary rays • Shake down whole centre line 	Rycotewood Furniture Centre Fine Furniture Competition + Robert Ingham Designs – chair. Robert Ingham
1.9			4500 × 790 × 50	<ul style="list-style-type: none"> • Brown staining minimal • Shake in first two thirds • Less shake in last third • Minimal sapwood • Visible medullary rays 	Richard Fox - sculpture. Richard Fox

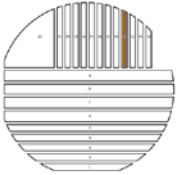

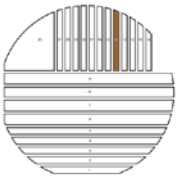

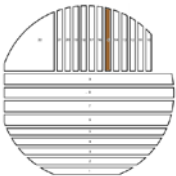

OneOak sawn timber catalogue

#	Board position	Photograph	Dimensions l × mean w × t mm	Description	End User Check online catalogue for latest details
1.10			4500 × 400 × 35	<ul style="list-style-type: none"> • Clean • Slight brown staining near base • Pronounced taper 	Rycotewood Furniture Centre Fine Furniture Competition
1.11		 <p align="right">Top right</p>	4500 × 150 × 35	<ul style="list-style-type: none"> • Interesting wavy edge • Pronounced taper 	Rycotewood Furniture Centre Fine Furniture Competition
1.12		 <p align="left">Top left</p>	4500 × 470 × 35	<ul style="list-style-type: none"> • Brown stain in first metre • Clusters of tight knots in top half 	Rycotewood Furniture Centre Fine Furniture Competition

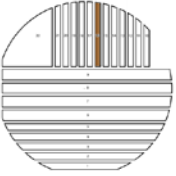

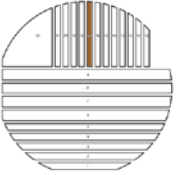

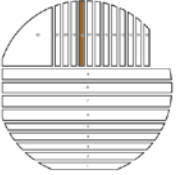

OneOak sawn timber catalogue

#	Board position	Photograph	Dimensions l × mean w × t mm	Description	End User Check online catalogue for latest details
1.13		 Top right	4500 × 200 × 35	<ul style="list-style-type: none"> • Brown stain in first metre • Clusters of tight knots in top half • Slightly wider than 1.12 	Rycotewood Furniture Centre Fine Furniture Competition
1.14		 Top left	4500 × 495 × 35	<ul style="list-style-type: none"> • Brown stain in first metre • Clusters of tight knots in top half • Slightly wider than 1.13 	Rycotewood Furniture Centre Fine Furniture Competition
1.15		 Top right	4500 × 235 × 35	<ul style="list-style-type: none"> • Brown stain in first metre • Clusters of tight knots in top half • Slightly wider than 1.14 	Rycotewood Furniture Centre Fine Furniture Competition

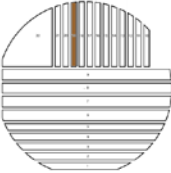

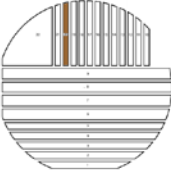
OneOak sawn timber catalogue

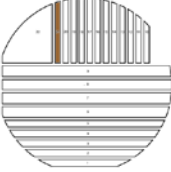
#	Board position	Photograph	Dimensions l × mean w × t mm	Description	End User Check online catalogue for latest details
1.16		 Top left	4500 × 485 × 32	<ul style="list-style-type: none"> • Pronounced medullary rays • Almost matched pair with 1.17 	Dunford Woodwork - door & frame. Rollo Dunford Wood
1.17		 Top right	4500 × 260 × 35	<ul style="list-style-type: none"> • Pronounced medullary rays • Almost matched pair with 1.16 	Dunford Woodwork - door & frame. Rollo Dunford Wood
1.18		 Top left	4500 × 430 × 35	<ul style="list-style-type: none"> • Quite quartered • Medullary rays less pronounced than in 1.16 and 1.17 • Relatively clean • Parallel figure • Some shake 	Rhodas Design - green oak outdoor furniture. Rhodas Irving

OneOak sawn timber catalogue

#	Board position	Photograph	Dimensions l × mean w × t mm	Description	End User Check online catalogue for latest details
1.19		 Top right	4500 × 260 × 35	<ul style="list-style-type: none"> • Quite quartered • Medullary rays less pronounced than in 1.16 and 1.17 • Relatively clean • Parallel figure • Some shake 	Rhodas Design - green oak outdoor furniture. Rhodas Irving
1.20		 Top left	4500 × 370 × 35	<ul style="list-style-type: none"> • Reasonably straight • Parallel figure 	Rycotewood Furniture Centre Fine Furniture Competition
1.21		 Top right	4500 × 260 × 35	<ul style="list-style-type: none"> • Reasonably straight • Parallel figure • Large knot 1.5m from base 	Rycotewood Furniture Centre Fine Furniture Competition

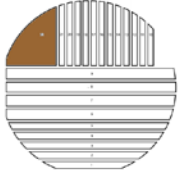





OneOak sawn timber catalogue

#	Board position	Photograph	Dimensions l × mean w × t mm	Description	End User
1.22			4500 × 160 × 200	•	<p>Check online catalogue for latest details</p> <p>Wallingford Museum – timber frame scale model.</p>

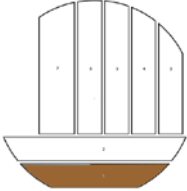

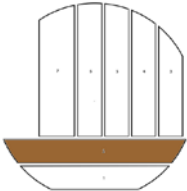

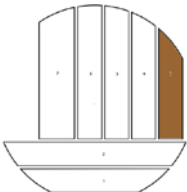

OneOak sawn timber catalogue

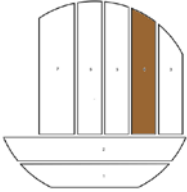
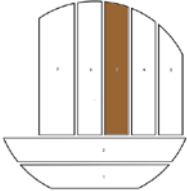

LENGTH 2

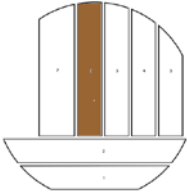
#	Board position	Photograph	Dimensions l × mean w × t mm	Description	End User
2.1			4350 × 600 × 105	<ul style="list-style-type: none"> • Clean board • Interesting and attractive markings • Good figure 	Wooden Creatures – Jeff Soan
2.2			4350 × 670 × 105	<ul style="list-style-type: none"> • Quite wild grain • Shake down centre • Base half contains diagonal grain 	
2.3			4350 × 270 × 105	<ul style="list-style-type: none"> • Clean except for a few attractive tight knots in base half • Narrow board with curved edges 	

OneOak sawn timber catalogue

#	Board position	Photograph	Dimensions l × mean w × t mm	Description	End User
2.4			4350 × 385 × 105	<ul style="list-style-type: none"> • Quite clean 	
2.5			4350 × 415 × 105	<ul style="list-style-type: none"> • Quite clean • Centre board 	Rycotewood Furniture Centre Schools seating projects
2.6			4350 × 425 × 105	<ul style="list-style-type: none"> • Clean except for mid section that has shake and some rot 	Rycotewood Furniture Centre Schools seating projects

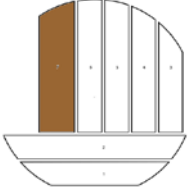





OneOak sawn timber catalogue

#	Board position	Photograph	Dimensions l × mean w × t mm	Description	End User
2.7			4350 × 380 × 185	<ul style="list-style-type: none"> • Base quarter clean • Middle half clean • Top quarter clean with sapwood coming through 	Oxon & Bucks Division, BWA + Rycotewood Furniture Centre Fine Furniture Competition

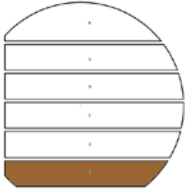

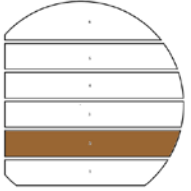

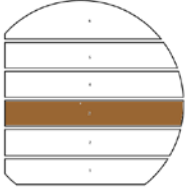

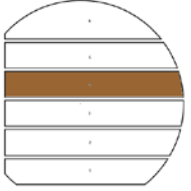

OneOak sawn timber catalogue

LENGTH 3

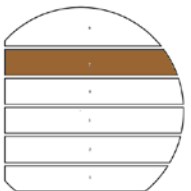
#	Board position	Photograph	Dimensions l × mean w × t mm	Description	End User
3.1			2750 × 450 × 80	<ul style="list-style-type: none"> • Large dead wood hole in centre • Some useful timber at base and top ends 	Rycotewood Furniture Centre Schools seating projects
3.2			2750 × 515 × 80	<ul style="list-style-type: none"> • Significant rot in centre • Top half reasonably clean 	Rycotewood Furniture Centre Schools seating projects
3.3			2750 × 560 × 80	<ul style="list-style-type: none"> • Centre board • Significant shake down centre 	Building

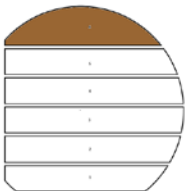
OneOak sawn timber catalogue

#	Board position	Photograph	Dimensions l × mean w × t mm	Description	End User
3.4			2750 × 565 × 80	<ul style="list-style-type: none"> • Much cleaner than 3.3 • Centre shows rot and some brown staining • Interesting deformity as a result of occluded branch in top half 	
3.5			2750 × 550 × 80	<ul style="list-style-type: none"> • Surprisingly clean • Three significant knots at two thirds along board • An interesting board 	Rhodas Design - green oak outdoor furniture. Rhodas Irving
3.6			2750 × 525 × 125	<ul style="list-style-type: none"> • 	

OneOak sawn timber catalogue

